

# ACCU-Series™ Pump Panel for Agricultural Irrigation

## User's Manual

460 VAC, 3 Phase Supply



**Nidec**  
All for dreams



01/04/2016 Rev. B

## Table of Contents

---

Safety.....	3
Hazard Categories.....	3
General Precautions.....	4
Introduction.....	6
References.....	6
Contacts and Ordering.....	7
Technical Information.....	8
Storage/Transportation.....	10
Unpacking the Drive Panel.....	10
Verify Delivery .....	10
Inspect for Damage.....	11
Lifting.....	11
Mechanical Installation.....	13
Before Installation.....	13
Mounting.....	13
Electrical Installation.....	14
General Wiring Practices.....	14
Wiring Schematic.....	15
Input Power Connection.....	17
Output Connection.....	17
Panel Wiring.....	17
Grounding.....	18

Operation.....	18
Basic Operation.....	20
Keypad.....	21
Safety.....	22
Maintenance/Troubleshooting.....	23
Maintenance.....	23
Factory Settings.....	24
Auto Identification .....	25
Product Registration.....	27
Notices.....	27

## Safety

This manual has been created to assist qualified electrical personnel in the handling, installation, setup and maintenance of the ACCU-Series™ Pump Panels. There are inherent risks associated with electrical AC drive panels and this manual is not intended to cover all aspects of electrical safety or local codes. Proper installation by local codes, NEC and NFPA is required.

Please review and understand the warnings and dangers provided in this document, the AD1000 drive manual and panel enclosure. Failure to follow could result in property damage, serious injury or death.

### Hazard Categories

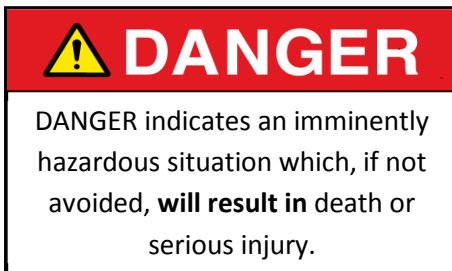

**! DANGER**

DANGER indicates an imminently hazardous situation which, if not avoided, **will result in** death or serious injury.

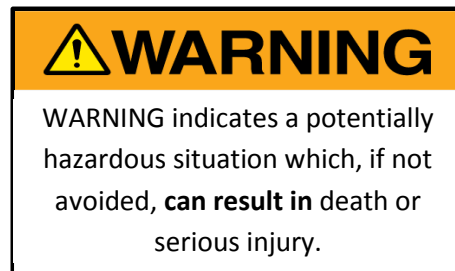

**! WARNING**

WARNING indicates a potentially hazardous situation which, if not avoided, **can result in** death or serious injury.

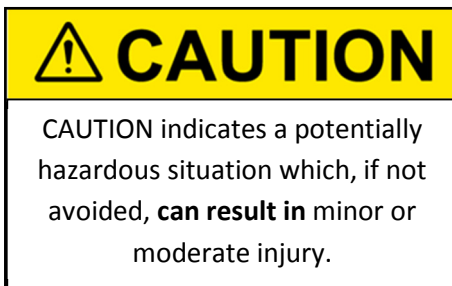

**! CAUTION**

CAUTION indicates a potentially hazardous situation which, if not avoided, **can result in** minor or moderate injury.

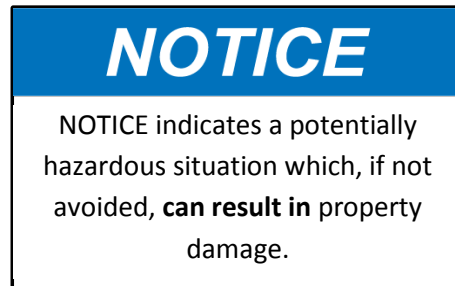

**NOTICE**

NOTICE indicates a potentially hazardous situation which, if not avoided, **can result in** property damage.

**General Safety Precautions**

Be sure to observe the following general safety precautions at all times while operating, handling, and/or servicing the Drive Panel.

 <b>CAUTION</b>
The ACCU-Series™ Pump Drive Panel could start up automatically after an input voltage interruption if the external run command is on.

 <b>CAUTION</b>
The ACCU-Series™ Pump Drive Panel should <b>ONLY</b> be installed by a qualified electrician.

 <b>CAUTION</b>
All standard electrical safety procedures must be followed:
<ul style="list-style-type: none"><li>• Never touch anything within the drive panel until you check that it is not hot and/or live.</li><li>• Always wear insulated or rubber safety shoes and safety goggles.</li><li>• Never work alone.</li><li>• Never connect any grounded meters or oscilloscopes to the system.</li><li>• Never remove safety shields.</li></ul>
<b>Always use extreme caution when handling components or taking measurements inside the enclosure.</b>

 **WARNING**

When the ACCU-Series™ Pump Panel with Input Disconnect is connected to the line power, the Motor Terminals T1, T2, and T3 are live even if the motor is not running. Do not make any connections when the Drive Panel is connected to the line. Disconnect and lock out power to the drive before servicing.

 **WARNING**

Even when power is removed from the input terminals of the ACCU-Series™ Pump Panel, there may be dangerous voltage (from external sources) on the terminals of the relay outputs.

 **WARNING**

Dangerous voltage is present when input power is connected. After disconnecting the supply, wait at least 5 minutes (to let the intermediate circuit capacitors discharge).

## Introduction

The ACCU-Series™ Pump Panel is a preconfigured drive package for the agricultural industry. Due to a weatherproof enclosure, the cabinet is designed to operate safely outdoors with proper installation. This user manual was written to cover the installation and operation of the 460VAC three phase models. Operating HP ranges from 30 HP to 200 HP. Refer to the AD1000 drive manual for additional drive options and information.

Each ACCU-Series™ Pump Panel includes:

- NEMA 3R weatherproof cabinet
- AD1000 pump drive rated at 50° C
- Thru door circuit breaker protection
- Input line reactor
- Fully functional drive keypad with programming port in door
- Drive controlled fan for energy savings and longer life
- Local controls on cabinet door
- Quick start setup menu
- Interior light
- Full suite of pumping software features (See AD1000 manual for complete list)
- Designed to complement US Motors® brand vertical HOLLOSHAFT® motors for optimal compatibility

## References

For additional information, reference the following related manuals:

- ACCU-Series™ Pump Panel Quick Start Guide
- AD1000 Drive Manual
- AD1000 Programming Manual

## Contacts and Ordering

### Sales

Nidec Motor Corporation  
8050 West Florissant Avenue  
St. Louis, MO 63136  
Phone: + (888) 637-7333

### Service

Contact: + (800) 566-1418

### Part Number Ordering and Options

The ACCU-Series™ Pump Panel part number, located on the nameplate on the inside of the door, is coded to describe the configuration and options present. Use Table 1 below to translate the part number into a description of the panel.

Table 1: Part Number Ordering Guide

ACCU-Series™ Pump Panel Part Number Ordering Guide and Available Options							
MODEL	AMPS (50° C)	VOLTAGE	PHASE	MOUNTING	OPTIONS		
AGP	0036	2 – 230 V	1 – 1 Ø	A – WALL MOUNT	0 – NONE	0 – NONE	0 – NONE
	0047	4 – 460 V	3 – 3 Ø	B – FLOOR STAND 12" HIGH	1 – LOAD REACTOR	1 – LIGHTNING ARRESTOR	1 – REMOTE KEYPAD
	0059			C – FLOOR STAND 24" HIGH			
	0069						
	0112						
	0140						
	0162						
	0189						
	0270						

For example, the part number "AGP004743A001" would indicate a 36 Amp, 460V, 3 Phase, Wall Mounted drive panel with a remote keypad.



**Technical Information**

Table 2: Motor Information

Drive Panel PN	Motor HP	Motor FLA	Motor PN
AGP003643xxxx000	30	<b>35</b>	HO30V2BLF
AGP004743xxxx000	40	<b>45</b>	HO40V2BLG HO40V2BLF
AGP005943xxxx000	50	<b>57</b>	HO50V2BLG
AGP006943xxxx000	60	<b>68</b>	HO60V2SLG
AGP011243xxxx000	75	<b>87</b>	HO75V2SLG
AGP014043xxxx000	100	<b>114</b> <b>115</b>	HO100V2SLG HO100V2SLGX
AGP016243xxxx000	125	<b>142</b> <b>143</b>	HO125V2SLG HO125V2SLGX
AGP018943xxxx000	150	<b>164</b> <b>165</b>	HO150V2SLG HO150V2SLGX
AGP027043xxxx000	200	<b>222</b>	HO200V2SLH HO200V2SLHX

Table 3: Shipping Specifications

Model	Weight	Shipping Material Weight	Total Weight (Pounds)	Shipping Dimensions H" x W" x D"
AGP003643	254.4	50	304.4	60" x 30" x 28"
AGP004743	311.8	50	361.8	60" x 30" x 28"
AGP005943	425.3	60	485.3	66" x 46" x 30"
AGP006943	430.3	60	490.3	66" x 46" x 30"
AGP011243	493.6	60	553.6	66" x 46" x 30"
AGP014043	498.6	60	558.6	66" x 46" x 30"
AGP016243	617.1	70	687.1	78" x 46" x 32"
AGP018943	667.7	70	737.7	78" x 46" x 32"
AGP027043	654.7	80	734.7	80" x 46" x 36"

Table 4: Model Specifications

Model	Nominal HP	Amps 50° C	Enclosure Frame	Circuit Breaker Amps	Circuit Breaker kA	Enclosure Dimensions H" x W" x D"
AGP003643	30	36	1	50	14	41" x 24" x 12"
AGP004743	40	47	1	60	14	41" x 24" x 12"
AGP005943	50	59	2	80	14	53" x 36" x 16"
AGP006943	60	69	2	100	14	53" x 36" x 16"
AGP011243	75	112	2	150	14	53" x 36" x 16"
AGP014043	100	140	2	175	18	53" x 36" x 16"
AGP016243	125	162	3	225	18	65" x 36" x 16"
AGP018943	150	189	3	250	30	65" x 36" x 16"
AGP027043	200	270	4	400	30	67" x 36" x 22"

Table 5: Torque Settings

Drive A1		Circuit Breaker CB1		Power Distribution Block PDB1-3	
Model	Power Terminal Torque (Lb-In)	Current Rating (Amps)	Terminal Torque (Lb-In)	Line Terminal Torque (Lb-In)	Load Terminal Torque (Lb-In)
AGP003643	10.6	50	120	40	61
AGP004743	17.6	50	120	40	61
AGP005943	22.1	80	120	120	61
AGP006943	22.1	100	120	120	61
AGP011243	88.4	150	120	120	61
AGP014043	88.4	175	225	120	61
AGP016243	88.4	225	225	275	192
AGP018943	88.4	250	225	275	192
AGP027043	199.1	400	450	192	120

Table 6: Torque Settings

Line Reactors					
Input Line Reactor L1 3% Impedance			Output Line Reactor L2 1.5% Impedance (Optional)		
Current (Amps)	Wire Size (AWG)	Terminal Torque (Lb-In)	Current (Amps)	Wire Size (AWG)	Terminal Torque (Lb-In)
40	8	20	40	10	20
52	8	20	52	8	20
65	6	30	65	8	30
77	4	35	77	6	35
124	4	275	124	4	120
156	1/0	275	156	2	275
180	1/0	275	180	1/0	375
240	2/0	500	180	1/0	375
302	4/0	275	302	2*1/0	500

## Storage/Transportation

Storing the drive panel in its original packaging until it reaches its final installation site helps protect the equipment and helps prevent damage to the exterior. If you plan to store the drive panel after receipt, replace it in its original packaging and store it in a clean, dry area where the ambient temperature is between -13 to +158 °F (-25 to +70 °C). If the drive panel must be shipped to another location, use the original shipping material.

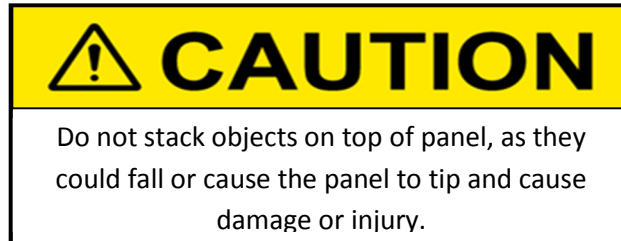

## Unpacking the Drive Panel

- Handle the unit carefully to avoid damage to the internal components, frame, or exterior.
- Lift the drive out of its shipping carton with a suitable lifting apparatus and place it on a flat surface (see figure 1 on page 11).
- Be sure to save the original packaging for future storage or transportation.

## Verify delivery

Check that you received the drive that was ordered as well as any options or accessories. Contact your supplier regarding any discrepancies (see "Contacts and Ordering" on Page 7).

## Inspect for Damage

Inspect the drive for any damage that may have occurred during shipment. Remove the cover, if present, and visually examine the insides for obvious problems. If damage is found, do not operate the drive. Report the problem immediately to the supplier.



## Drive Panels Lifting

### When lifting drives:

- Always work with another person. The weight, size, and shape of the drive is such that two people are required to handle it.
- Use cut-resistant gloves.
- A lifting apparatus is required to lift the panel (see Figure 1 on page 11).
- Depending on the size of the drive panel, either 2 or 4 lifting holes will be present.
- Attach lifting chains to the top lifting eyebolts (see Figure 1 for location of lifting holes) and hoist the drive upwards. See Figure 1 for the proper hoisting method.
- Raise the drive from a horizontal position (the back of the controller resting on a pallet) to the vertical, upright position.
- The bottom of the drive has a mounting flange which prevents the drive from standing in a vertical position. If the drive is rested on the mounting flange, it may tip over.

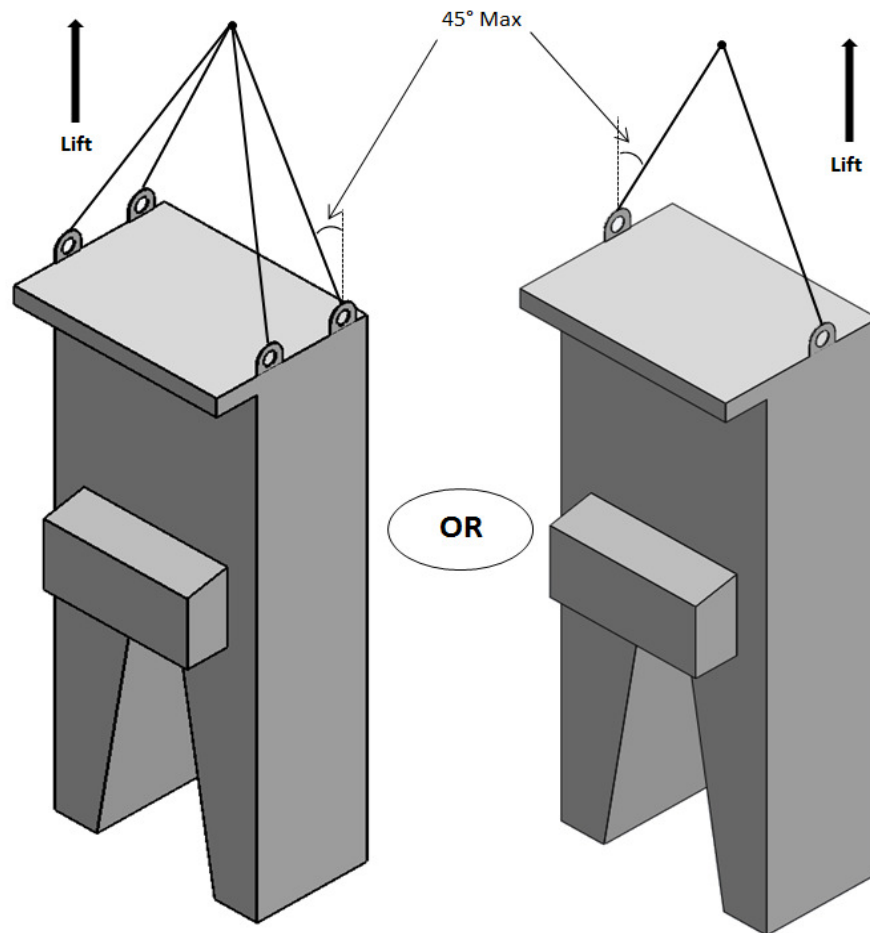

Figure 1: Proper Lifting Technique



## WARNING

### HANDLING, LIFTING, AND TOPPLING HAZARD

- The cabinet is top heavy, keep area near cabinet clear of personnel and property.
- Ensure Drive Panel is mounted properly and securely.
- When mounting and lifting, ensure the load is steady and balanced to prevent tipping.

**Failure to follow these instructions could lead to death, serious injury, or equipment damage.**

## Mechanical Installation

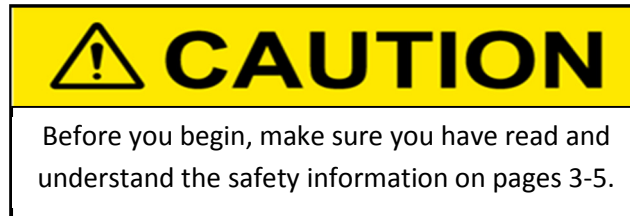

### Before installation

1. Open the front door of the drive enclosure. To open the door, turn the circuit breaker or disconnect handle assembly to the OFF position and rotate the center latch handle counter-clockwise. Use a slotted screwdriver to turn the top and bottom ¼-turn latches counter-clockwise to unlatch the door.
2. Visually verify that all internal mounting and terminal connection hardware is properly seated, securely fastened, and undamaged.
3. Close and secure the drive panel door by rotating the center latch handle clockwise to the locked position. Use a slotted screwdriver to turn the top and bottom ¼-turn latches clockwise to latch the door.

### Mounting

Observe these requirements when mounting the drive enclosure:

- Mount the wall-mounted drive enclosure on a flat, rigid, noncombustible vertical surface, capable of supporting the drive enclosure weight.
- Mount the floor-mounted drive enclosure on a flat, solid surface capable of supporting the enclosure weight.
- If drilling for conduit entry, take care to prevent metal chips from falling on parts and electronic printed wiring boards.
- Do not mount the drive on hot surfaces.
- When attaching wall-mountable drives to their mounting surfaces, use fasteners rated for the weight of the driver, the expected shock and vibration of the installation, and the expected environment. See table 3 on page 8 for drive enclosure weights.
- Use water-tight rated conduit hubs to make connections between the conduit and the UL Type 3R enclosures.
- Do not obstruct the air intake on the unit.

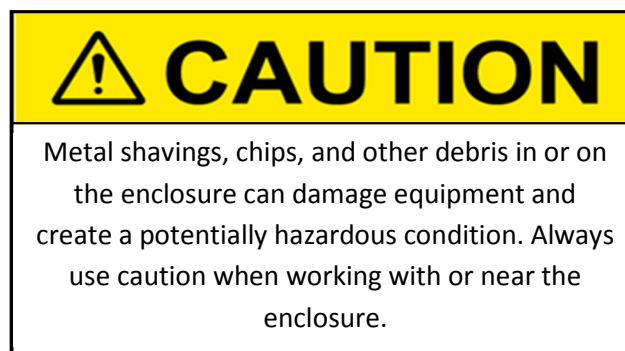

## Electrical Installation

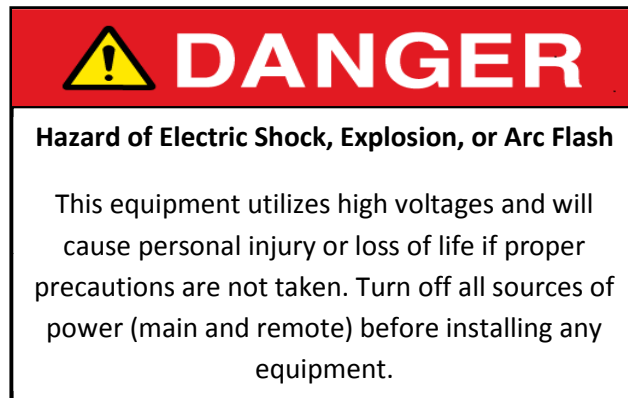

### General Wiring Practices

Good wiring practice includes separating the control circuit wiring from all power wiring. Power wiring to the motor requires the maximum possible separation from all other power wiring, from the same drive and from other devices. **Do not run power and/or control of multiple power wiring in the same conduit.** Separation reduces the possibility of coupling electrical transients from power circuits into control circuits or from motor power wiring into other power circuits.

When wiring the field drive:

- Before applying power ensure that the wiring termination points have been checked for proper torque. See Tables 5 and 6 on page 9 for torque values.
- Use metallic conduit or VFD cable for all drive wiring. Do not run control and power wiring in the same conduit.
- Separate metallic conduits carrying power wiring or low-level control wiring by at least 3 inches (76 mm).
- Separate existing, non-metallic conduits or cable trays used to carry power wiring from metallic conduit carrying low-level control wiring by at least 12 inches (305 mm).
- Whenever power and control wires are crossing, the metallic conduits and non-metallic conduits or trays must cross at right angles.

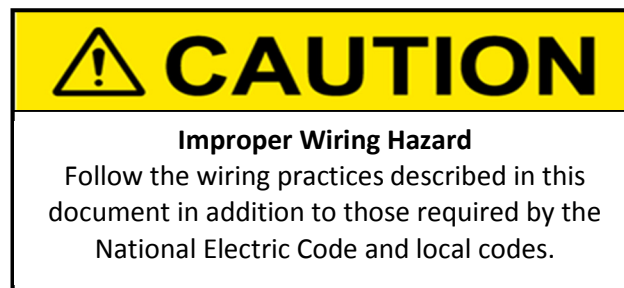

Figure 2a: Wiring Schematic

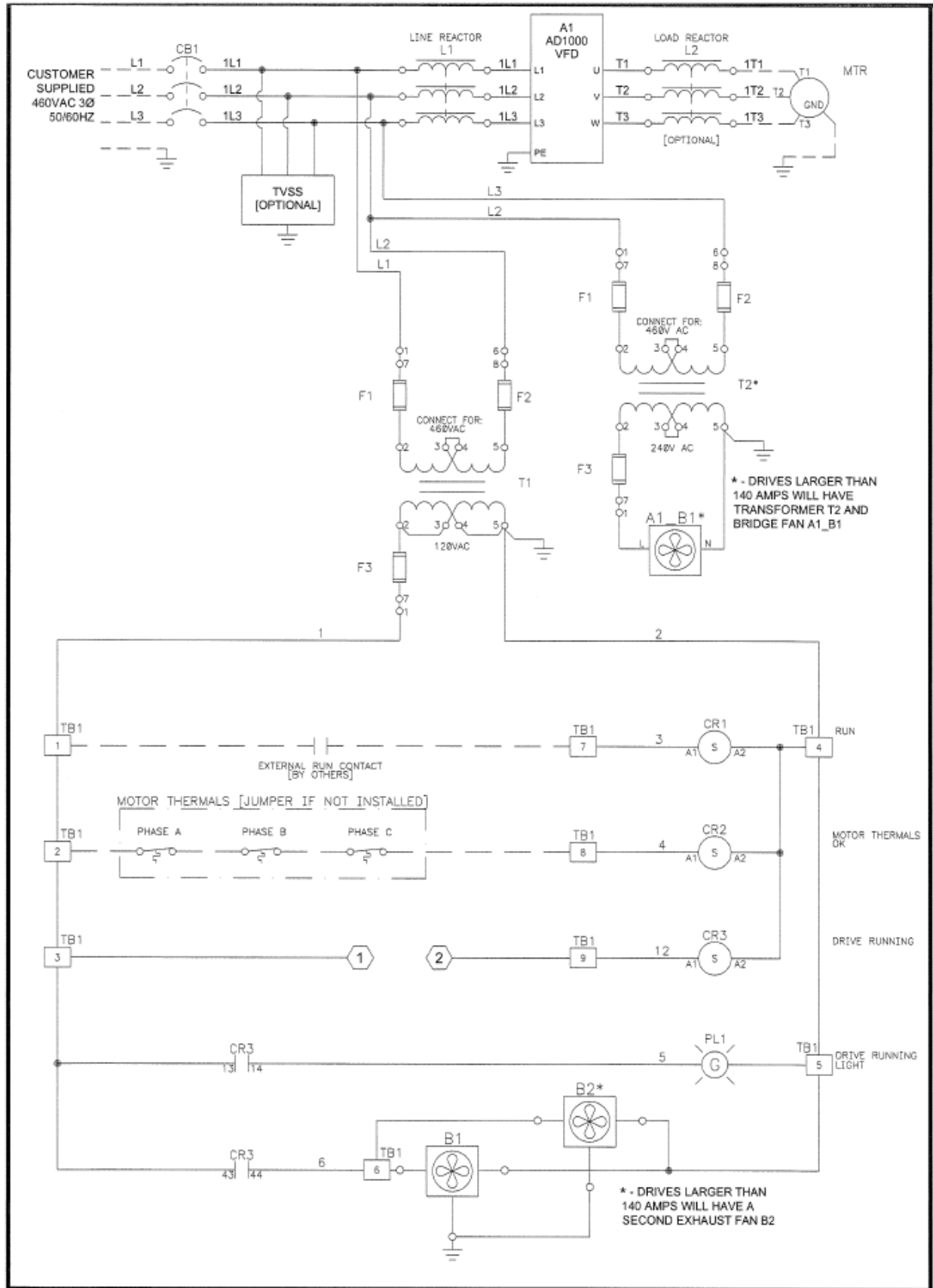
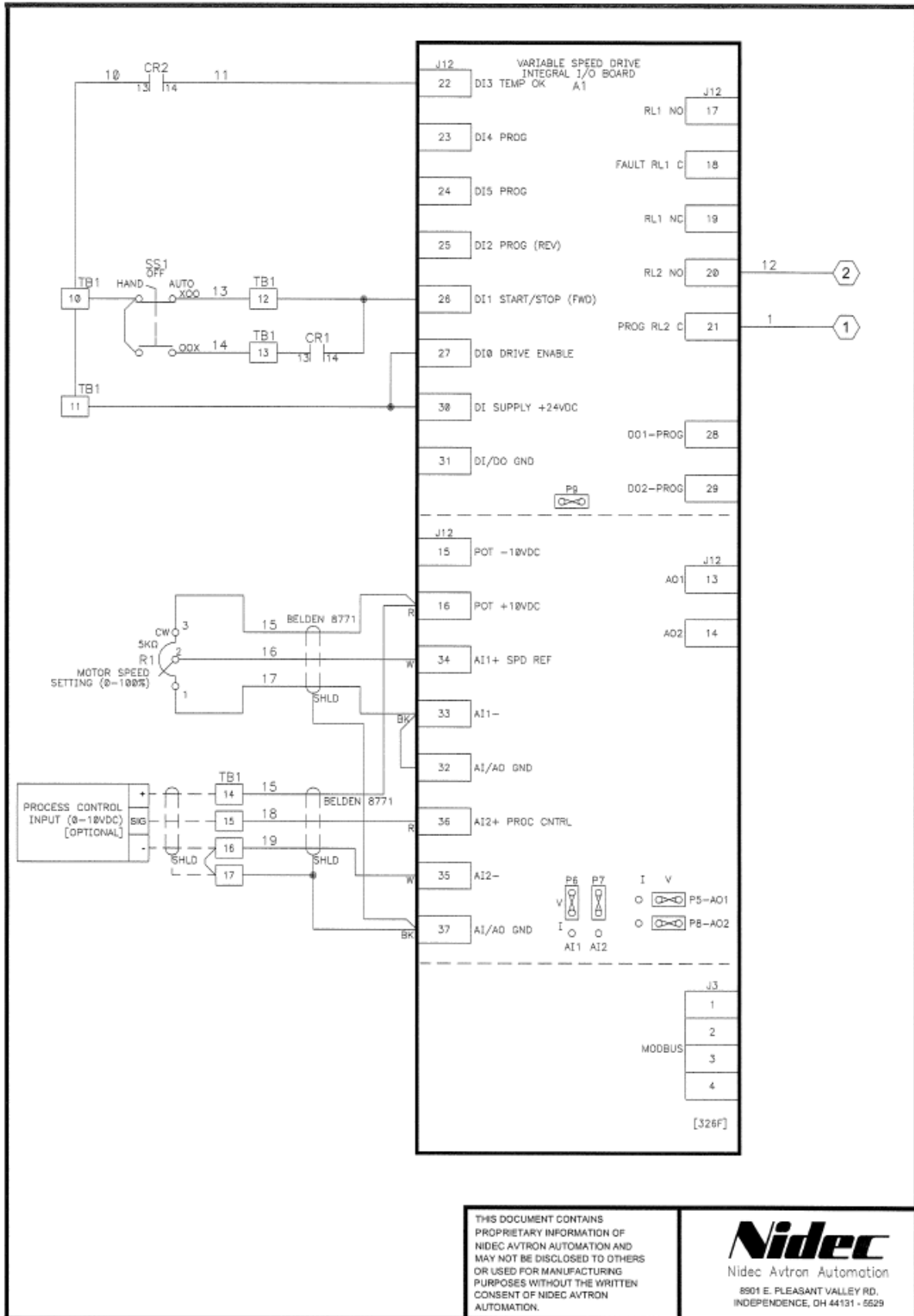



Figure 2b: Wiring Schematic



THIS DOCUMENT CONTAINS PROPRIETARY INFORMATION OF NIDEC AVTRON AUTOMATION AND MAY NOT BE DISCLOSED TO OTHERS OR USED FOR MANUFACTURING PURPOSES WITHOUT THE WRITTEN CONSENT OF NIDEC AVTRON AUTOMATION.



### Input Power Connection

The field drive operates from a three-phase, 48-63 Hz, 460 VAC +/-10% supply connected to the disconnecting means. Refer to Tables 1 and 4 for drive input voltages and ratings.

Connect leads from power supply to connections on circuit breaker CB1 marked L1, L2, and L3. Connect ground wire to the upper ground terminal block. Refer to Figure 2 on page 15 for locations.

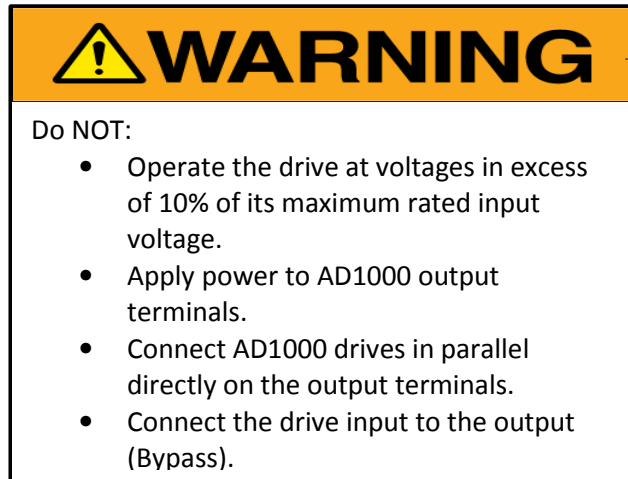

### Output Connection

**Output drive filtering is recommended if the cable length between the drive panel and motor exceeds 20 feet. Extended cable length is a factor that may contribute to voltage overshoots at the motor in excess of MG-1 Part 31 levels.**

The pump motor must be wired to the output of the drive. If an output reactor is connected to the drive output, wire the motor to the connections marked 1T1, 1T2, and 1T3 on the output reactor (L2). If no output reactor is connected, wire the motor directly to the output connections on the drive marked U, V, and W. Be sure to connect a ground wire from the output to the ground connection on the drive. The use of a shielded VFD cable for the output connections is recommended for the purposes of protecting against noise generated by the drive as well as returning high frequency current into the drive instead of flowing through the motor frame. The shielded cable must be connected to ground at both ends, both to the ground terminal of the motor and to the cabinet output terminal, connected at its turn to ground bars. Refer to Figure 2a on page 15 for locations.

### Panel Wiring

Before drive operation, several additional components must be wired. Refer to Figure 2 on page 15 for all mentioned locations.

An external run contact must be wired in to bridge the connection between terminal blocks TB1-1 and TB1-6. This is the external run contact that must be installed in order to run the drive in automatic mode (see *Operation* on page 17). Optionally, motor thermal switches may be installed for the purpose of protecting against an overheating motor. Wire the phase A, B, and C motor thermal switches in series

between TB1-2 and TB1-7. If motor thermals are not installed, wire a jumper wire between TB1-2 and TB1-7 instead. Motor overheat safety features will not be functional if the switches are not installed.

A 0-10V (or 4-20MA with correct jumper setting) analog transducer (process control input) may optionally be wired to the I/O board. Connect the analog transducer to the connection points located at TB1-14, TB1-15, and TB1-16. Connect a ground wire from the analog transducer to the connection at TB1-17. A shielded cable is recommended for this connection.

### Grounding

Ground the drive according to the National Electrical Code and all local codes. To ground the drive:

- Connect a copper wire from the ground bar terminal on the drive to the ground connection on the drive output.
- Connect the ground wire from the input power source to the upper ground terminal block.
- Refer to Figure 2 on page 14 to locate the necessary ground connections.
- Verify that the resistance to ground is 1  $\Omega$  (Ohm) or less. Improper grounding causes intermittent and unreliable operation.

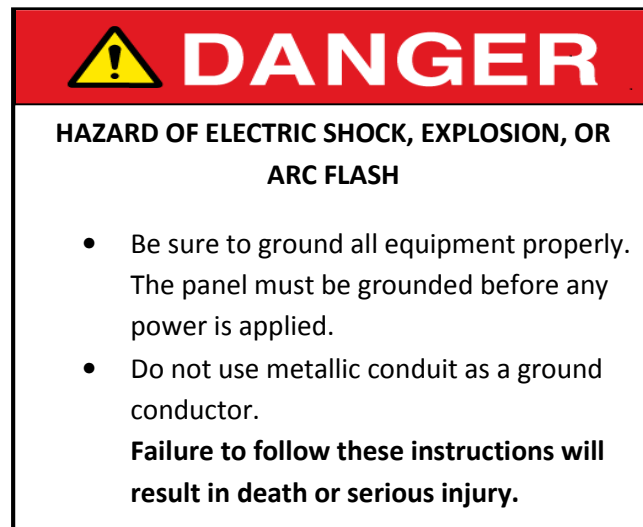

### Operation

The ACCU-Series™ Pump Panels should only operate in an environment between 32°F and 122°F (0-50°C) and in humidity below 95%.





1. **Communication Port** – Used to plug the drive keypad into the outside of the panel.
2. **ON LED** – Illuminates to indicate the drive is on and running.
3. **Hand-Off-Auto (HOA) Switch** – Used to select the operation mode of the panel.
  - a. To operate in manual mode, the switch is turned to the HAND position. In this mode, the drive will run and remain on until the user manually turns the HOA switch back to the OFF position.
  - b. To operate in automatic mode, the switch is turned to the AUTO position. In this mode, the drive will automatically turn on and off based on input from an external control source (such as a timer). See the ACCU-Series™ Pump Panel user manual for additional information on wiring in an external control source for this operation mode.
4. **Main Disconnect Switch** – Used to turn the power on and off. While the switch is in the ON position the panel door will be locked and all internal electrical components will be live (provided the external power supply is connected and activated).
5. **Handle Lock** – Used to lock/unlock the panel door. A padlock may be used with this handle for further protection.
6. **Speed Selection Potentiometer** – Used to select the desired speed for the motor to run at.

**Basic Operation**

To operate the ACCU-Series™ Pump Panel, first ensure that the panel is properly installed and that all switches on the front panel are set to the OFF position. Close and lock the panel door by rotating the lower handle latch. Ensure that the external 460V supply is active. Next, locate the main disconnect rotating handle (see Figure 3). Rotate the handle to the ON position and allow a few minutes for the drive to fully power on. The panel door will not open while the handle is set to this position.



Figure 3: Main Disconnect Switch

To operate the drive in manual operation mode, turn the HOA switch to the HAND position (see Figure 3). The indicator light beside HOA switch labeled ON should illuminate and the internal fan should begin rotating to indicate the drive is on and running. To select the desired motor speed, rotate the speed selection potentiometer (see Figure 5) to the desired motor speed. The drive will automatically adjust motor power to maintain a constant motor speed based on the setting. The hand mode is used to allow the operator to manually turn the pump on and off. When in this mode, the drive will remain running until manually turned off by turning the Hand-Off-Auto switch back to the OFF position (see below). In the hand mode the motor speed is adjusted by the Speed Selection Potentiometer.



Figure 4: Hand-Off-Auto Switch



Figure 5: Speed Selection Potentiometer

To operate the drive in automatic mode, turn the mode selector switch to the AUTO position (see Figure 4). The auto mode is used in conjunction with an external run controller to automatically turn the pump on and off based on input from the external controller (such as a timer). When input power is received from the controller, the drive will run. The indicator light beside the mode selector switch labeled ON should illuminate and the internal fan should begin rotating to indicate the drive is on and running. When this power is disconnected, the drive will turn off. If no external run contact is wired to the panel (see *Electrical Installation*), automatic mode will not function. To select the desired motor speed, rotate the Speed Selection Potentiometer (Figure 5) to the desired speed. The drive will automatically adjust motor power to maintain a constant motor speed based on the setting.

To manually cease operation of the drive in either mode, rotate the Hand-Off-Auto switch to the OFF position. Next, rotate the main disconnect switch to the OFF position. Turn off and remove all sources of power before attempting to open the panel door. Rotate the lower handle latch to unlock the panel door. With all switches set to the OFF position, the panel door can now be opened for installation or servicing purposes.

### **Keypad**

The ACCU-Series™ Pump Panel may also be monitored using the provided remote keypad. To do this, plug one side of the communication cable into the keypad and the other side into the port located on the face of the front panel door. The keypad will load configuration information from the drive upon connecting to it for the first time. The keypad allows the user to remotely navigate basic operation functions of the drive panel and provides detailed monitoring and alarm information. It is also used for programming various features and functions into the drive as well as startup settings. Refer to section 4.2 of the AD1000 programming manual for detailed information regarding the interface and functionality of the keypad as well as a complete layout of the menu structure.

ON	LED	- On: AD1000 ready (pre-charged completed) - Blinking: AD1000 ready (pre-charged completed) and in manual mode
FAULT	LED	- On: One or more fault occurred - Blinking: there are one or more alarms
RUN	LED	- On: AD1000 is working - Blinking: the braking chopper is working
STOP	KEY	Decelerates the motor in a controlled way until it stops ***
MAN	KEY	- Sets the AD1000 in manual mode - Starts it if it is in manual * mode
AUTO	KEY	- Sets the AD1000 in Auto mode: the run command and speed reference come from an external source **
RESET	KEY	- Clears faults - Acknowledges alarms - Fault test LED
ENTER	KEY	- Selects a submenu or parameter - Enters in edit mode for a selected parameter - Accepts a new value in edit mode
CANCEL	KEY	- Returns to the monitor page - Rejects any modification to parameter values in edit mode
SHIFT	KEY	- Accesses the second group of functions: Shall be pressed before the desired function keys (example SHIFT + 9 accesses the communication Menu)

Figure 5: Key and LED Functionality

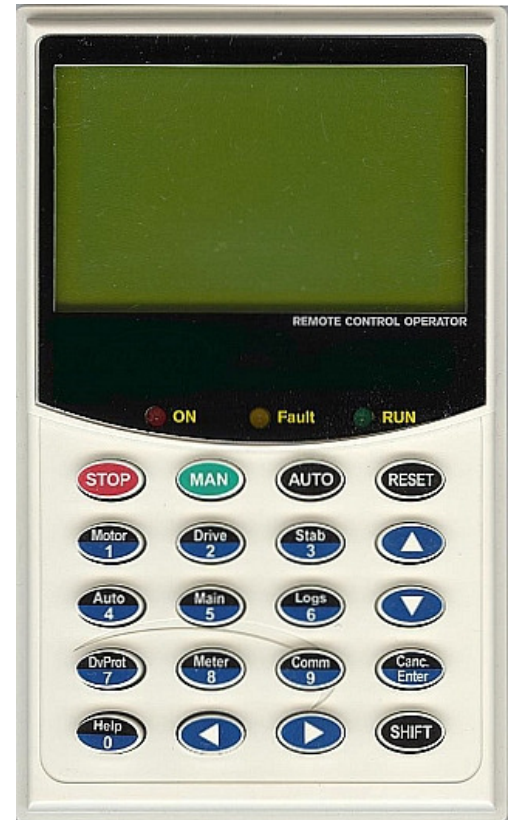

Figure 6: Keypad Layout

**Safety**

The ACCU-Series™ Pump Panel includes several safety features. If the pump motor gets too hot, built in over temperature switches will cause the drive to fault and the motor will coast to a stop. EXT FAULT will be displayed on the keypad display. Once the fault occurs the drive will check for the motor to cool down and try to restart the motor for a period of 65 minutes. After 65 minutes the drive will need to be manually reset via the keypad or the main power will need to be cycled by turning the main disconnect OFF and then back ON. During operation, the main disconnect switch (Figure 3) may trip. If this occurs, turn the switch to the OFF position and then back to the ON position. The drive is also programmed by factory settings (page 22) to not run below 10% of its maximum RPM to avoid an overheating motor.

**Additional Features**

All of the listed additional features are inactive by default. Reference the appropriate feature in the programming manual for information on how to activate the desired feature.

- **Soft Fill** – Fill pipes gradually in order to prevent burst pipes and extend pump life. Reference AD1000 programming manual, chapter 9 section 42.
- **Prevent Frost Damage** – If temperatures drop below a set temperature in sleep mode the drive will run at a constant, low speed to prevent damage. Reference AD1000 programming manual, chapter 9 section 33.

- **Anti-Blocking** – Prevents pump blockage during long periods of inactivity by starting the pump periodically. Reference AD1000 programming manual, chapter 9 section 31.
- **Low Inlet Pressure** – Automatically switches to a lower pressure set-point should inlet pressure decline to avoid incurring damage to the pump. Reference AD1000 programming manual, chapter 9 section 45.
- **Process PID** – Control the pump based on water pressure or water flow instead of motor speed using a built-in PID. Reference AD1000 programming manual, chapter 9 section 34-41 and annex G examples 1 through 3.
- **Multi-pump Control** – Control multiple auxiliary pumps operating together to meet flow or pressure requirements to save energy and prolong equipment lifetime. Reference AD1000 programming manual, chapter 9 section 43.
- **Motor Pause** – Stop the motor automatically if water level, pressure, flow, or other variables reach a user-defined threshold. Reference AD1000 programming manual, chapter 9 section 43.
- **Well Draw Down Control** – Reduce to a lower, energy-saving flow rate when the ground water level drops below a specified threshold. Reference AD1000 programming manual, chapter 9 section 44.

## Maintenance/Troubleshooting

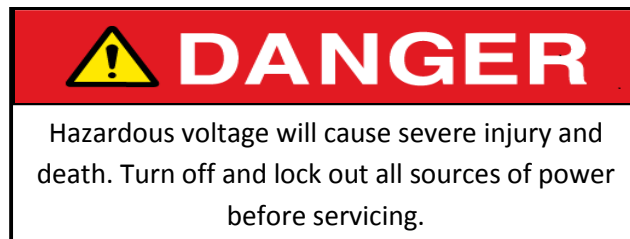

### Preventative Maintenance

To keep the ACCU-Series™ Pump Panel safe and in good working condition, the panel should be routinely maintained using the following guidelines. In general, the panel should be kept clean and free of dust/debris, the interior should be kept dry, and all connections should be kept tight. Dust can cause a lack of airflow which can diminish the performance of heat sinks and cooling fans. Dust on electrical devices can cause malfunction or failure. Air used to clean dusty surfaces must be oil-free and dry. The interior of the panel should always be kept completely dry. In addition, the panel should not be subjected to large amounts of mechanical vibration in storage, operation, or while servicing as this can lead to sub-standard connections. Connections should be checked occasionally to ensure they are tight and in good working condition.













### Factory Settings



















If the drive settings are ever reset to default, certain factory settings will need to be re-established through the keypad that were not needed to be set on the initial startup.

First, change to programming level 3 by pressing the  key followed by the  key and typing 0003 into the popup window and press  to confirm.

From the drive keypad main screen, press the  key followed by the  key to enter the parameter search window. Type the number of a parameter listed in the table below (without the decimal point) to go to the corresponding parameter. Press the  key to select the parameter. Using the arrow keys and/or the numerical keys, change the default value of the parameter to the value shown in the table below. Repeat this for each parameter listed.



Parameter	Name	Change Value To:
16.05	DO3 Select	SW1.11 – Pulses Enabled
32.01	Main Speed Ref Sel	AI1
32.23	Max Neg Ref	0.000 pu
32.28	Skip Freq Band 1	0.050 pu
32.29	Skip Freq 1	0.050 pu
33.12	HOA Start/Stop Type	Level
33.21	Auto OnOff Enable	On
34.01	Auto Reset Enable	On
34.02	Auto Reset Time	300
34.03	Auto Reset Attempt	13
34.04	Reset Memory Time	350
36.09	External Fault	Coast Stop
45.06	Lower Limit	0.000 pu
45.11	PID Ref Src Sel 1	Fixed
45.12	PID Fdb Src Sel 1	AI2







In addition to changing the above parameters, perform the following steps to complete the re-establishment of factory settings:





1. From the main keypad screen (press  followed by ) , press the  button to change the keypad to Auto operation mode. If not already in Auto mode, the keypad will display the message "Auto Press enter to confirm". Press the  key to confirm.
2. From the main keypad screen, press the  key to highlight the first display. Navigate down until the 5<sup>th</sup> line is highlighted. Press  to select this display. From the opened menu, select the *Speed Reference* submenu and press  . From this submenu, select the *Speed Reference* option and press  . The speed reference from the front panel speed potentiometer will now be displayed as the first line of the keypad main screen.
3. From the main keypad screen, press the  key followed by the  key. Type the code 5868 into the popup window and press  to change to programming level 4. Press the  key followed by the  key and enter 1399 into the popup window and press  to bring up parameter 1399. Change the value of this parameter from IEC to NEMA. Press  followed by  to return to the main screen. Press  followed by  and enter 0003 into the popup screen and press  to return to programming level 3 (standard programming level).

## AUTO-IDENTIFICATION

For better performance of the drive, it is necessary to correctly set the value of the voltage drop over stator resistance. If desired, this section may be skipped.

If known, change the parameter **Voltage Drop Over Rs [07.03]**, located by pressing  followed by  , navigating to the *MOTOR ID 1* submenu and pressing  . If the value of this parameter is not known it is possible to use the following auto-identification process:

1. Before beginning the test, ensure the keypad is in manual mode. Do this by pressing the  key. The keypad will display the message "Man Press enter to confirm" if not already in manual mode. Press the  key to confirm.
2. Press  followed by  , navigate to the *MOTOR ID 1* submenu and press  .
3. To enable the test, set the parameter **Static Test ID 1 [07.01]** to *Test On* and press  . A dialog box should pop up on the keypad screen. Press  again to confirm.
4. Ready the drive for a short test run by turning the Hand-Off-Auto switch on the door of the enclosure from "OFF" to "HAND".

- 5 Press the  key to begin the test. The test should take around 15-30 seconds and the motor should perform a short test run. The keypad will read "Test Running" and the STOP key may be used to abort the test if needed.
- 6 After the screen indicates that the test has completed, press  followed by  to exit the testing screen. Finally, change the parameter **Static Test ID 1 [07.01]** to *Test done*. Press  to confirm the change.
- 7 If the value of the voltage drop over stator resistance is not known and it is not possible to perform the auto-identification, refer initially (for 4 pole motors) to the table below:

30 HP	40 HP	50 HP	60 HP	75 HP	100 HP	125 HP	150 HP	200 HP
0.031 pu	0.029 pu	0.027 pu	0.026 pu	0.025 pu	0.023 pu	0.022 pu	0.021 pu	0.020 pu

- 8 Ensure that the parameter **Static Test ID 1 [07.01]** is set to *Test Done* before proceeding.
- 9 The power must be cycled after auto-identification before the drive will run. Turn the main disconnect switch to the OFF position and allow a few minutes for the drive to fully power off. Turn the main disconnect switch back to the ON position and allow a few minutes for the drive to fully power on.

## Product Registration

It is recommended that the ACCU-Series™ Pump Panel be registered with the manufacturer upon receipt of the product. To register your product visit: [www.usmotors.com/VFDregistration](http://www.usmotors.com/VFDregistration)

Registration of this product with complete data will provide the user with a Registration Certificate and enable faster service should a problem arise.

For additional product information and technical support please visit:  
[www.usmotors.com/ACCU-Series/PumpPanel](http://www.usmotors.com/ACCU-Series/PumpPanel)

### Notices

© 2015 Nidec Motor Corporation. All rights reserved.  
8050 West Florissant Avenue  
St. Louis, MO 63136  
888.637.7333

No part of this publication may be copied, reproduced, or reduced to any electronic media or machine-readable format without the prior written permission of Nidec Motor Corporation. The information contained in this manual is considered accurate to the best knowledge of the supplier at the time of publication. The manufacturer, however, assumes no liability for errors that may exist. The supplier reserves the right to change data and specifications without notice. All trade designations are provided without reference to the rights of their respective owners.

Printed in the United States of America