



# Appendix E

## Power Factor Correction Capacitors

### CAUTIONS:

- Do not over correct the power factor of products described in this catalog. Correcting full load power factor beyond approximately 95% will potentially result in severe non-warranty damage to motor and driven equipment.
- Refer to your Emerson Technical Representative for assistance on applying Power Factor Correction Capacitors on Multi-Speed Motors.
- On single voltage motors with Part Winding Start (PWS), Double Delta or Wye Delta Starting, Emerson recommends the capacitor be connected to the motor side of contactors 1-2-3 in the motor starter.
  - If this is unacceptable, then two separate capacitors should be supplied, each with one-half of the desired KVAR rating. One capacitor should be connected to the 1-2-3 motor leads, the second connected to 4-5-6 (or 7-8-9 as applicable).
- Do not apply Power Factor Correction Capacitors to a variable frequency drive. Serious damage to the VFD will result if capacitors are used between the motor and drive. Consult the drive supplier.
- Refer to your Emerson Technical Representative if any questions exist.

### APPLICATION:

Application of Power Factor Correction Capacitors to three phase Squirrel Cage Induction Motors (SCIM) is beneficial because the power used by industrial and municipal facilities has two components.

1. Real Power (KW) which produces work.
2. Reactive Power (KVAR) needed to generate the rotating magnetic field required for the operation of electric motors. No useful work is performed by this component.

Reactive Power is sometimes called "wattless power" because inductive electrical equipment such as motors must take from the electrical distribution system more current than is necessary to do the work involved. The ratio of working current to total current is called "Power Factor". The function of Power Factor Correction Capacitors is to increase the power factor by supplying the "wattless power" when installed at or near inductive electrical equipment.

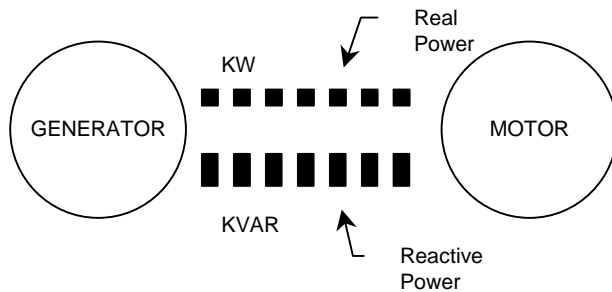

This is an illustration of an SCIM under partially loaded conditions without Power Factor Correction Capacitors (PFCC). Here the power feeder line must supply useful real power and reactive or magnetizing currents.

Installing a PFCC near the same motor will supply the reactive or magnetizing current required to operate it. The total current required of the power feeder line is reduced to the value of the useful real current only.

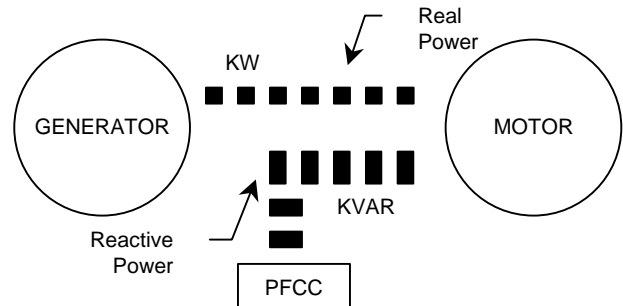



# Appendix E

## Power Factor Correction Capacitors

---

Power Factor Correction Capacitors can lower electrical costs. In many areas the cost of electricity includes a penalty charge for low power factor. Installation of Power Factor Correction Capacitors on the distribution system within the plant makes it unnecessary for the utility to supply the wattless or the non-working power required by the inductive electrical equipment connected to it. Savings the utility realizes in reduced generation, transmission, and distribution costs are passed on to the plant in the form of lower electrical bills.

Savings are also possible in the form of increased KVA capacity of plant electrical distribution systems. Installation of PFCC's to furnish the non-productive current requirements makes it possible to increase the plant connected load, as much as 15 to 20 percent, without a corresponding increase in size of transformers, conductors and protective devices making up the distribution system which services the load.

### PRICING EXAMPLE:

Listed in the engineering data section of this catalog is the maximum amount of KVAR allowed to be applied to the specific product described. This generally corrects the motor's full load power factor to 95%. Should a Customer require correction to a lower value, apply the following formula to obtain the required KVAR. KVAR is the unit for rating PFCC and is equal to 1000 volt-amperes of reactive power. This indicates how much reactive power the capacitor will provide.

Example: How many KVAR's are needed to improve the motors existing full load power factor to 92%?

$$\text{Actual Power} = \frac{\text{Volts} \times \text{Amps} \times \%P.F. \times 1.732}{1000}$$

$$\text{Actual Power} = \frac{460 \times 582 \times 0.843 \times 1.732}{1000}$$

$$\text{Actual Power} = 390.89 \text{ KW}$$

Motor is 500 HP, 1200 RPM, 460 Volts with 84.3% Full Load Power Factor, ODP Horizontal Standard Efficient Type "R" with 582 Full Load Amps.

Obtain from Table 33-1 (next page) the KW Multiplier at the intersection of 84% original power factor and 92% desired power factor: PF Multiplier = 0.22.

$$\text{KVAR} = 390.89 \times 0.22 = 86$$

Performance Data indicates 125 KVAR is maximum, 86 is needed; correction to 92% is possible.

From the 480 Volt PFCC Pricing Chart, the closest rating to 86 required KVAR but not exceeding 125 maximum KVAR is 90. Select 90 KVAR PFCC with \$2395 List Price and Discount Symbol DS-3PC, to correct full load power factor to 92.0%.



# Appendix E

## Power Factor Correction Capacitors

### KW MULTIPLIERS:

TABLE 33-1																
ORIGINAL POWER FACTOR	KW MULTIPLIERS TO DETERMINE CAPACITOR KVAR REQUIRED															
	CORRECTED POWER FACTOR															
	0.80	0.81	0.82	0.83	0.84	0.85	0.86	0.87	0.88	0.89	0.90	0.91	0.92	0.93	0.94	0.95
0.60	0.583	0.609	0.635	0.661	0.687	0.713	0.740	0.766	0.793	0.821	0.849	0.877	0.907	0.938	0.970	1.004
0.61	0.549	0.575	0.601	0.627	0.653	0.679	0.706	0.732	0.759	0.787	0.815	0.843	0.873	0.904	0.936	0.970
0.62	0.516	0.542	0.568	0.594	0.620	0.646	0.673	0.699	0.726	0.754	0.782	0.810	0.840	0.871	0.903	0.937
0.63	0.483	0.509	0.535	0.561	0.587	0.613	0.640	0.666	0.693	0.721	0.749	0.777	0.807	0.838	0.870	0.904
0.64	0.451	0.474	0.503	0.529	0.555	0.581	0.608	0.634	0.661	0.689	0.717	0.745	0.775	0.806	0.838	0.872
0.65	0.419	0.445	0.471	0.497	0.523	0.549	0.576	0.602	0.629	0.657	0.685	0.713	0.743	0.774	0.806	0.840
0.66	0.388	0.414	0.440	0.466	0.492	0.518	0.545	0.571	0.598	0.626	0.654	0.682	0.712	0.743	0.775	0.809
0.67	0.358	0.384	0.410	0.436	0.462	0.488	0.515	0.541	0.568	0.596	0.624	0.652	0.682	0.713	0.745	0.779
0.68	0.328	0.354	0.380	0.406	0.432	0.458	0.485	0.511	0.538	0.566	0.594	0.622	0.652	0.683	0.715	0.749
0.69	0.299	0.325	0.351	0.377	0.403	0.429	0.456	0.482	0.509	0.537	0.565	0.593	0.623	0.654	0.686	0.720
0.70	0.270	0.296	0.322	0.348	0.374	0.400	0.427	0.453	0.480	0.508	0.536	0.564	0.594	0.625	0.657	0.691
0.71	0.242	0.268	0.294	0.320	0.346	0.372	0.399	0.425	0.452	0.480	0.508	0.536	0.566	0.597	0.629	0.663
0.72	0.214	0.240	0.266	0.292	0.318	0.344	0.371	0.397	0.424	0.452	0.480	0.508	0.538	0.569	0.601	0.635
0.73	0.186	0.212	0.238	0.264	0.290	0.316	0.343	0.369	0.396	0.424	0.452	0.480	0.510	0.541	0.573	0.607
0.74	0.159	0.185	0.211	0.237	0.263	0.289	0.316	0.342	0.369	0.397	0.425	0.453	0.483	0.514	0.546	0.580
0.75	0.132	0.158	0.184	0.210	0.236	0.262	0.289	0.315	0.342	0.370	0.398	0.426	0.456	0.487	0.519	0.553
0.76	0.105	0.131	0.157	0.183	0.209	0.235	0.262	0.288	0.315	0.343	0.371	0.399	0.429	0.460	0.492	0.526
0.77	0.079	0.105	0.131	0.157	0.183	0.209	0.236	0.262	0.289	0.317	0.345	0.373	0.403	0.434	0.466	0.500
0.78	0.052	0.078	0.104	0.130	0.156	0.182	0.209	0.235	0.262	0.290	0.318	0.346	0.376	0.407	0.439	0.473
0.79	0.026	0.052	0.078	0.104	0.130	0.156	0.183	0.209	0.236	0.264	0.292	0.320	0.350	0.381	0.413	0.447
0.80	0.000	0.026	0.052	0.078	0.104	0.130	0.157	0.183	0.210	0.238	0.266	0.294	0.324	0.355	0.387	0.421
0.81		0.000	0.026	0.052	0.078	0.104	0.131	0.157	0.184	0.212	0.240	0.268	0.298	0.329	0.361	0.395
0.82			0.000	0.026	0.052	0.078	0.105	0.131	0.158	0.186	0.214	0.242	0.272	0.303	0.335	0.369
0.83				0.000	0.026	0.052	0.079	0.105	0.132	0.160	0.188	0.216	0.246	0.277	0.309	0.343
0.84					0.000	0.026	0.053	0.079	0.106	0.134	0.162	0.190	0.220	0.251	0.283	0.317
0.85						0.000	0.027	0.053	0.080	0.108	0.136	0.164	0.194	0.225	0.257	0.291
0.86							0.000	0.026	0.053	0.081	0.109	0.137	0.167	0.198	0.230	0.264
0.87								0.000	0.027	0.055	0.083	0.111	0.141	0.172	0.204	0.238
0.88									0.000	0.028	0.056	0.084	0.114	0.145	0.177	0.211
0.89										0.000	0.028	0.056	0.086	0.117	0.149	0.183
0.90											0.000	0.028	0.058	0.089	0.121	0.155
0.91												0.000	0.030	0.061	0.093	0.127
0.92													0.000	0.031	0.063	0.097
0.93														0.000	0.032	0.066
0.94															0.000	0.034
0.95																0.000



# Appendix E

## Power Factor Correction Capacitors

480 Volt									
KVAR	TYPE	NUMBER OF CELLS	WEIGHT (LBS)	LIST PRICE	KVAR	TYPE	NUMBER OF CELLS	WEIGHT (LBS)	LIST PRICE
1	AMP	1	11	\$345	75	ICS	1	61	\$1,970
1.5	AMP	1	11	\$351	80	ICS	1	67	\$2,130
2	AMP	1	11	\$357	90	ICS	1	72	\$2,375
2.5	AMP	1	11	\$363	100	ICS	1	76	\$2,679
3	AMP	1	11	\$377	120	ICS	2	161	\$3,300
4	AMP	1	11	\$404	125	ICS	2	161	\$3,348
5	AMP	1	12	\$347	150	ICS	2	175	\$3,967
6	AMP	1	12	\$420	175	ICS	2	195	\$4,144
7.5	AMP	1	12	\$529	200	ICS	2	209	\$4,321
10	AMP	1	13	\$550	225	ICS	3	248	\$5,015
12.5	AMP	1	13	\$651	250	ICS	3	268	\$5,721
13.5	AMP	1	13	\$683	275	ICS	3	283	\$6,250
15	AMP	1	14	\$732	300	ICS	3	297	\$6,553
17.5	AMP	2	17	\$792	325	ICS	4	341	\$7,136
20	AMP	2	18	\$844	350	ICS	4	355	\$7,820
22.5	AMP	2	18	\$904	400	ICS	4	384	\$8,817
25	AMP	2	19	\$935	425	ICS	5	429	\$9,295
27.5	AMP	2	19	\$995	450	ICS	5	443	\$9,942
30	AMP	2	20	\$1,036	475	ICS	5	457	\$10,575
32.5	AMP	3	24	\$1,122	500	ICS	5	472	\$11,079
35	AMP	3	24	\$1,208	525	ICS	6	516	\$11,750
37.5	AMP	3	25	\$1,238	550	ICS	6	530	\$12,431
40	AMP	3	25	\$1,269	575	ICS	6	545	\$12,975
45	AMP	3	26	\$1,401	600	ICS	6	560	\$13,341
50	AMP	4	31	\$1,441					
55	AMP	4	32	\$1,527					
60	AMP	4	33	\$1,614					

Options	List Adder
Q-3 Fuses	5%
Q-3 Fuses with Blown Fuse Lights	10%
No Fuses	Standard

All units are manufactured and warranted by GE / Aerovox.  
 Standard lead time 2 to 3 weeks.

**DISCOUNT SYMBOL: DS-3PC**



# Appendix E

## Power Factor Correction Capacitors

600 Volt									
KVAR	TYPE	NUMBER OF CELLS	WEIGHT (LBS)	LIST PRICE	KVAR	TYPE	NUMBER OF CELLS	WEIGHT (LBS)	LIST PRICE
1.5	AMP	1	11	\$391	60	ICS	1	54	\$1,879
2	AMP	1	11	\$401	75	ICS	1	61	\$2,157
2.5	AMP	1	11	\$412	100	ICS	1	76	\$2,688
3	AMP	1	11	\$423	120	ICS	2	161	\$3,490
4	AMP	1	11	\$448	125	ICS	2	161	\$3,582
5	AMP	1	12	\$453	150	ICS	2	175	\$3,958
6	AMP	1	12	\$481	175	ICS	2	195	\$4,308
7.5	AMP	1	12	\$518	200	ICS	2	209	\$4,892
10	AMP	1	13	\$534	225	ICS	3	248	\$5,759
12.5	AMP	1	13	\$616	250	ICS	3	268	\$6,182
15	AMP	1	14	\$739	275	ICS	3	283	\$6,487
17.5	AMP	2	17	\$789	300	ICS	3	297	\$7,076
20	AMP	2	18	\$877	325	ICS	4	341	\$7,795
22.5	AMP	2	18	\$929	350	ICS	4	355	\$8,083
25	AMP	2	19	\$947	400	ICS	4	384	\$9,218
27.5	AMP	2	19	\$1,009	425	ICS	5	429	\$11,164
30	AMP	2	20	\$1,072	450	ICS	5	443	\$12,755
32.5	AMP	3	24	\$1,117	475	ICS	5	457	\$14,192
35	AMP	3	24	\$1,162	500	ICS	5	472	\$14,671
37.5	AMP	3	25	\$1,210	525	ICS	6	516	\$15,775
40	AMP	3	25	\$1,277	550	ICS	6	530	\$16,181
45	AMP	3	26	\$1,365	575	ICS	6	545	\$16,918
50	AMP	4	31	\$1,458	600	ICS	6	560	\$17,576

Options	List Adder
Q-3 Fuses	5%
Q-3 Fuses with Blown Fuse Lights	10%
No Fuses	Standard

All units are manufactured and warranted by GE / Aerovox.  
 Standard lead time 2 to 3 weeks.

**DISCOUNT SYMBOL: DS-3PC**



# Appendix E

## Power Factor Correction Capacitors

2400 Volt					4160 Volt				
KVAR	TYPE	NUMBER UNITS	WEIGHT (LBS)	LIST PRICE	KVAR	TYPE	NUMBER UNITS	WEIGHT (LBS)	LIST PRICE
25	ICC	1	64	\$1,846	25	ICC	1	64	\$1,846
50	ICC	1	64	\$2,020	50	ICC	1	64	\$2,020
75	ICC	1	64	\$2,150	75	ICC	1	64	\$2,150
100	ICC	1	69	\$2,471	100	ICC	1	69	\$2,471
125	ICC	1	76	\$2,653	125	ICC	1	76	\$2,653
150	ICC	1	81	\$2,813	150	ICC	1	81	\$2,813
175	ICC	1	86	\$2,938	175	ICC	1	86	\$2,938
200	ICC	1	92	\$3,101	200	ICC	1	92	\$3,101
225	ICC	1	103	\$4,787	225	ICC	1	103	\$4,787
250	ICC	1	103	\$4,914	250	ICC	1	103	\$4,914
275	ICC	1	114	\$5,072	275	ICC	1	114	\$5,072
300	ICC	2	149	\$5,354	300	ICC	1	149	\$5,354
325	ICC	2	154	\$5,552	325	ICC	2	154	\$5,552
350	ICC	2	159	\$5,696	350	ICC	2	159	\$5,696
375	ICC	2	165	\$5,824	375	ICC	2	165	\$5,824
400	ICC	2	171	\$6,000	400	ICC	2	171	\$6,000
425	ICC	2	181	\$7,589	425	ICC	2	181	\$7,589
450	ICC	2	192	\$7,928	450	ICC	2	192	\$7,928
475	ICC	2	192	\$8,034	475	ICC	2	192	\$8,034
500	ICC	2	192	\$8,221	500	ICC	2	192	\$8,221
525	ICC	2	203	\$8,517	525	ICC	2	203	\$8,517
550	ICC	2	214	\$8,613	550	ICC	2	214	\$8,613
575	ICC	3	248	\$8,702	575	ICC	2	248	\$8,702
600	ICC	3	254	\$8,824	600	ICC	2	254	\$8,824

Options	List Adder
Q-3 Fuses	5%
Q-3 Fuses with Blown Fuse Lights	10%
No Fuses	Standard

All units are manufactured and warranted by GE / Aerovox.  
 Standard lead time 2 to 3 weeks.

**DISCOUNT SYMBOL: DS-3PC**